

MAHOT

Kneading à la française
Up to 160 kg of dough*

The mixer that adapts to all types of dough:

- bread dough
- short dough
- pancake mix
- pizza dough



- **Batch programming through the use of automatic timers**

- ✓ Manual mode
- ✓ Semi-manual mode
- ✓ Automatic mode

- **Clear bowl cover with access door**

- **Exclusive, patented arm**

- ✓ Concave shape of the arm for a better aeration of the dough
- ✓ Self-braking system reducing the working time



- **Stainless steel bowl** to fully comply with health regulations

- **Silence and robustness**

The gearbox is made of a couple of spiral bevel gears enabling it to deliver the full motor power with no loss of energy



For more information:



Video



Commercial documentation

* Maximum dough capacity. Example for an average hydration rate of 60%. More information here.

Fork mixers with removable bowl MAHOT

General Features



- Removable stainless steel bowl with mechanic brake
- Patented Mahot mixing tool
- 2 tool speeds
- Stainless steel cover with access door
- 2 timers
- Hydraulic head lifting and bowl locking
- Driving by spiro-helical bevel gears
- 400 V - 3 phases + Earth - 50Hz (any other specific voltage available and free of charge providing that it is technically possible)
- IP 54

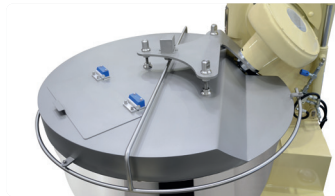
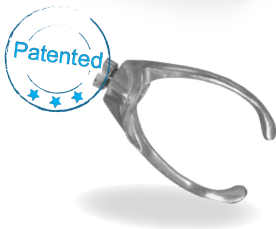

Stainless steel cover with access door

>> Specific rates and conditions apply

MB 1024 AH

Code: B503423CA

- Power: 8,4 kW
- Intensity: 18 A

Optional extra

>> Specific rates and conditions apply

Removable stainless steel bowl on trolley

Capacity - braked bowl	MB 1024 AH
Total bowl volume (l)	330
Max. dough capacity (kg)*	160
Weight (kg)	760
Dimensions (mm)	
Width (A)	1330
Height closed (B)	1715
Height open (B')	1790
Depth (C)	1500
Bowl height (D)	860
Bowl diameter Ø	1000

Dimensions without bowl: height 1715 mm x depth 1195 mm x width 1040 mm

*Example for an average hydration rate of 60%.
More information here.

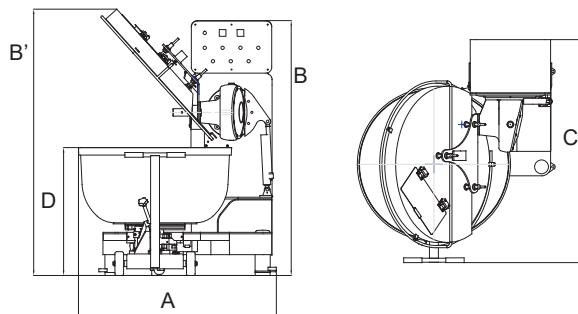

See conditions on page 5